



Gear Management Solutions™

3380 N. El Paso St., Colorado Springs, CO 80907

Visit our website at [www.LetsGoAero.com](http://www.LetsGoAero.com) For Assistance, please call 1-877-464-2376 or 719-630-3800

# LITTLEGIANT TRAILER™ LGT 1107 - T (Torsion based model)

## User Assembly and Operation Manual

**Read this owner's manual carefully before you begin using your Trailer.**

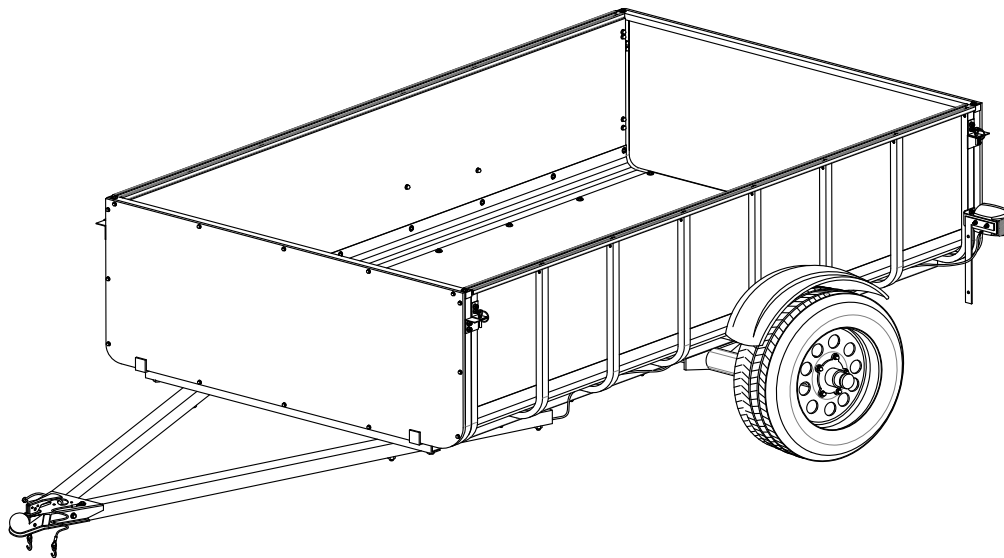

<b>SAFE USE &amp; OPERATION</b>	pg. 2
<b>SAFETY CHECKLIST</b>	pg. 2
<b>INSPECTION, MAINTENANCE AND CLEANING</b>	pg. 3
<b>PARTS IDENTIFICATION</b>	pg.9,10
<b>LITTLEGIANT TRAILER ASSEMBLY</b>	pg.11
<b>WARRANTY / REPAIR PROCEDURES</b>	pg.17
<b>TRAILER LICENSING NOTICE</b>	pg.17

### SAVE THIS MANUAL

Read the owner's manual over carefully before you begin using your trailer. You will need this manual for the safety warnings and precautions, operating procedures, parts list, inspection, and maintenance information. Keep this manual for continued reference.

## SAFE USE & OPERATION

Be sure to follow these guidelines to prevent possible hazards from misuse.

Do NOT exceed the trailer's maximum load weight capacity of 1,500 lbs. or exceed the trailer's bed size. The Gross Vehicle Weight Rating (G.V.W.R.) for the LittleGiant™ Trailer is 1,920 lbs, and is calculated as follows:

**The Empty Weight of the Trailer (420 lbs) + the maximum payload the trailer can carry (1,500 lbs) = 1,920 lbs G.V.W.R.**

2. Make sure the towing vehicle as well as the hitch is capable of towing the trailer and its payload. Check your vehicle and hitch owner's manual for tow ratings.
3. The tail light bulbs supplied with this trailer are for a 12 volt DC electrical system only. Do not attempt to power the light bulbs with any other type or voltage electrical current.
4. Always check to make sure the payload being transported is properly and safely secured in the trailer. Never place loads on one side only. Load the trailer evenly from side to side with 60% of the load forward of the axle (the tongue weight is 10% of the load, which does not include the weight of the trailer. The load is divided so that 90% of the load is over the axle and 10% is over the tongue). See diagrams below:

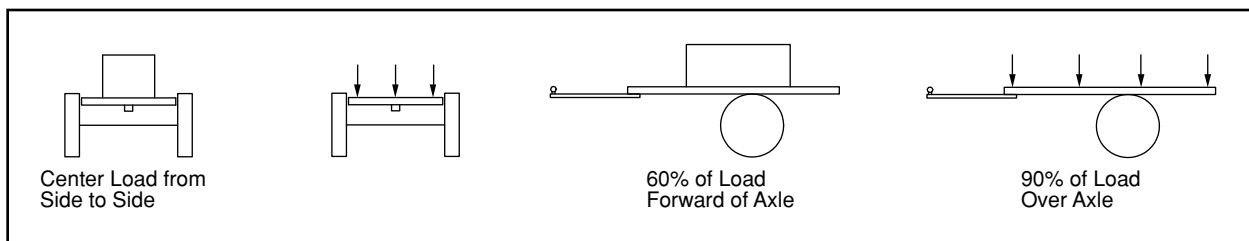

### Before Each Use

Trailers are generally not used everyday. Your trailer may sit for extended periods of time between uses making it very important to check all components thoroughly before each use. Following these simple instructions will maximize the life of your trailer and keep you safely transporting your cargo.

- Inspect the general condition of the trailer. Check for loose bolts and nuts, misalignment or binding of moving parts, cracked, bent, or broken parts, excessively worn safety cable, damaged tail lights/side running lights/wire harness, loose lug nuts, loose hitch connection, and any other condition that may affect its safe operation.
- Check your maintenance schedule to ensure that all routine maintenance matters are current. Perform any neglected maintenance by a qualified technician.
- Always check wheel lug nuts for proper tightness. When using trailer for the first time, check wheel lug nuts for proper tightness at 50 miles of travel. Before every subsequent use and at 500 mile intervals during every trip, check and tighten the tire lug nuts. Always ensure wheel bolts are tight. Torque to 50 – 75 ft.-lbs.
- Check the tires for wear and the tire pressure for proper inflation (30 PSI).
- Check the operation of all lights. Replace any faulty bulbs. Operating lights are mandatory on a trailer. Periodically check lighting when towing over long distances. Check the tightness of all connections.
- Make sure wiring is properly installed and secured to trailer to prevent from hanging and catching on any road debris.
- Make sure the safety cables are attached to the trailer and the towing vehicle. Criss-cross cables as necessary to prevent from hanging and catching on any road debris.
- Check and adjust your tow vehicle's tow height to make sure that the trailer is being towed level.
- Check that the trailer coupler is fastened securely onto the trailer ball. The LittleGiant Trailer is equipped with a 2" coupler and must be used with a 2" trailer ball. After assembly and attachment, pull up and down on the coupler to make sure the hitch ball is fitting snugly in the coupler. If the coupler is not secured properly, the ball could come loose while the trailer is in motion, possibly causing property damage, serious

### Steps for Determining Correct Load Limit

- (1) Locate the statement "The weight of cargo should never exceed XXX kg or XXX lbs" on your vehicle's placard.
- (2) This figure equals the available amount of cargo and luggage load capacity.
- (3) Determine the combined weight of luggage and cargo being loaded on the vehicle. That weight may not safely exceed the available cargo and luggage load capacity.
- (4) The trailer's empty weight is 420 lbs, combined with 1,500 lbs of payload is the 1,920 Gross Vehicle Weight Rating.



## WARNINGS

Failure to adhere to these recommendations may result in potential hazards from improper operation, including property damage and bodily injury.

- **Keep children away.** Be sure children are kept a safe distance from the trailer operating area.
- **Never sit or ride on the trailer.** Serious injury or death could occur.
- Whenever possible, park the trailer on a flat, level, paved surface and chock both tires to keep the trailer from accidentally moving.
- **When driving do not exceed the speed limit.** Braking time can be considerably longer when a vehicle is towing a loaded trailer. Excess speed is a major cause of vehicle-trailer accidents.
- **Do not overload trailer.** Overloading has adverse effects on handling, stopping, and on tires, and may cause property damage, serious personal injury, or death.
- **Make sure the coupler is secured properly to the hitch ball.** If not secured properly, the ball could come loose while the trailer is in motion, possibly causing property damage, serious personal injury, or death.
- **Tighten wheel lug nuts.** Failure to properly tighten wheel lug nuts and to check for proper tightness during travel may result in property damage or serious personal injury.

## Inspection, Maintenance, and Cleaning

All replacement parts, maintenance and repairs should be undertaken by certified and licensed technicians. The buyer assumes all risk and liability arising out of his or her repairs to the original product or replacement parts, or arising out of his or her installation of replacement parts.

- Once a year or every 6,000 miles, inspect the bearings for proper lubrication. Repack if necessary. Be sure to have a qualified technician re-pack the hub assembly and handle other maintenance items.
- To reduce friction between the coupler and hitch ball, apply a layer of heavy weight grease over the hitch ball. Lubrication of the coupler should be done periodically to stop corrosion and keep parts moving freely.
- When servicing, use only identical replacement parts. Only use accessories intended for use with this product. Approved accessories are available from Let's Go Aero.
- Any modifications made to the trailer or parts of the trailer will void the trailer warranty and release Let's Go Aero of any responsibility for damages, injuries, or accidents incurred.

### To Make Sure That the Trailer Ball is Completely Engaged in the Coupler Ball

Place coupler over the 2" trailer ball on your vehicle. Raise the locking lever to allow the coupler to drop fully onto the hitch ball. Press the locking lever down on the coupler to make sure the hitch ball is fitting snugly in the coupler. There should be no play between the hitch ball and the coupler. If there is play, tighten the adjustment nut until no play is present. If the adjustment nut is too tight, the handle will not lock.

To adjust coupler to ball, raise the locking lever, push up on the channel lock and turn nut to tighten or loosen the coupler. Proper adjustment is obtained when coupler is as tight as possible on the ball and locking lever can still be opened and closed.

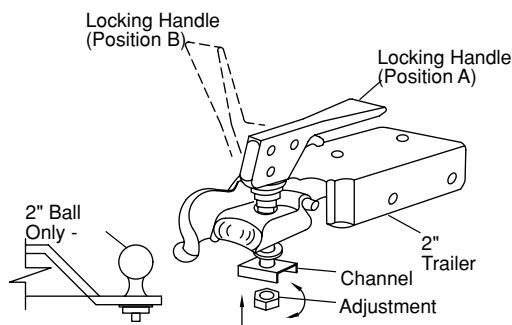

**Wiring**

- The LittleGiant Trailer has a four flat-connector wire style plug. This is a common pin hole configuration for the wiring of towables. Check to verify your vehicle’s wiring plug style. Should it differ, consult your local hitch installer for a wire plug adaptor.
- Always check all lights before towing for brake, running, signal, and side marker light operation. Make sure that all your connections are solid and that all wiring is in good condition. Should the brake, signal, or running lights not be working, first check that the vehicle’s lighting is operating properly.

**Note:** Bare, stripped or pinched wire will cause a short in the trailer, which will cause the vehicle fuse to blow. A solid ground is required for your lights to work properly. All contacts must be to bare metal. Light covers should be well maintained and kept clean. Be sure that your lights are always visible, not obstructed by your load.

**To test vehicle wiring:**

You will need a 12v light tester. Attach the wire clamp of the tester to the ground wire on the vehicle plug. Then touch the tester pin into one of the vehicle plug contacts. Turn on the corresponding vehicle operation, i.e., running lights. This will illuminate the tester light if the vehicle wiring is correct. Follow this same procedure for the signal and brake lights.

**To test the trailer wiring:**

Once you have confirmed that the vehicle trailer plug is operating properly, connect the trailer plug to your vehicle. Proceed to test each of the lights and power leads using your 12v light tester.

**Rubber Torsion Axle With The Suspension Built-In**

- Durability and Reliability.
- A Soft, Quiet, No Shock Ride With Independent Wheel Action.
- Easy to Assemble.
- Load Carrying Crossmember.
- Maintenance Free.
- Eliminates Sway.



**Bearing Inspection / Replacement**

The bearings should be inspected any time the hub is removed from the axle or at intervals as outlined in the maintenance schedule shown on page 8 of this manual. The bearing cones should show no signs of excessive wear or damage such as flat spots on the rollers, broken cages, pitting, or corrosion. The bearing cups that are pressed into the hub should also be checked for wear or damage. If the bearings do need to be replaced, follow the procedure as outlined and only use bearings that are approved for use in the following chart.

**IMPORTANT:** Both the bearing cup and bearing cone should be replaced any time a bearing is replaced.

The following procedure should be used for bearing cup replacement:

1. Carefully tap the existing bearing cup out of the hub using a brass punch
2. Clean the bore area after removing the cup to ensure there are no nicks or burrs.
3. Carefully tap the new bearing cup into the hub making sure the cup is seated against the bottom of the bore.

<b>BEARING REPLACEMENT &amp; INTERCHANGE</b>						
Axle Capacity	# of Bolts	Spindle Type	Inner Bearings		Outer Bearings	
			Cup	Cone	Cup	Cone
1000# - 1900#	4 or 5	Straight	L45410	L45449	L45410	L45449



***Bearing Lubrication***

Below is a listing of approved lubrication.

<b>LUBRICATION SPECIFICATIONS</b>	
<b>Grease</b>	
Dropping Point	230°C (446°F) Minimum
Viscosity Index	80 Minimum

The grease used should meet the requirements as shown in the chart above. The following amounts of grease should be used:

- 4 ounces to completely exchange the grease throughout the hub
- 1 1/2 - 3 ounces every (3) months or 1000 miles thereafter or as use requires

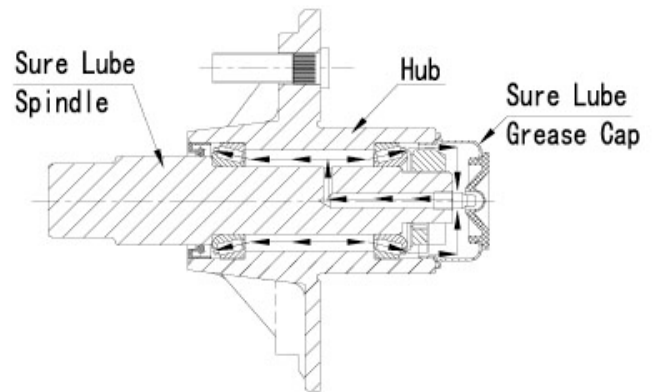

***Bearing Adjustment, Hub Installation, and Lubrication***

Bearing adjustment is a very important part of achieving maximum bearing life and trouble-free service. Most bearing failures can be attributed to improper bearing adjustment, normally due to the bearings being adjusted too tight.

Once all of the necessary inspections have been performed and the units have been properly lubricated, the following procedure should be used for reinstallation of the hubs:

1. Place the lubricated unit onto the same spindle from which it was removed. Make sure all of the components are reinstalled as they were removed.
2. Place the flat washer onto the spindle followed by the bend-leg washer, followed by the castle nut.
3. Finger-tighten the castle nut by hand without moving the hub.
4. Bend the legs of the bend-leg washer to the channel of the castle nut to ensure the castle nut will not back off.
5. The castle nut should be free to move with your fingers with only the bend-leg washer holding it in place and the hub should not have noticeable movement when pulled back and forth.
6. After assembling the hub, the grease is pumped through the hub via the grease zert in the end of the grease cap, then through the hole in the spindle to the space between the two bearings. The final step is to reinstall the dust cap.

## Rubber Torsion Axle Suspension

Except for periodic inspection of the fasteners used to attach the rubber torsion axle to the trailer frame and a visual inspection of the welds, no other suspension maintenance is required. However, all maintenance regarding hubs, drums, rotors, bearing, wheels, and tires, should be adhered to.

The torsion suspension system is a self-contained suspension system that is housed entirely inside the axle beam. Unlike the spring suspension system, the axle beam attaches directly to the trailer frame without the need for various mounting components. The action provided by the rubber torsion suspension system is unique from the leaf spring suspension providing several operating advantages including independent suspension and a virtually maintenance-free suspension system.

### How the Rubber Torsion Suspension System Works

The rubber torsion axles provide a much improved trailer ride relative to conventional spring axles through a unique arrangement of the steel torsion bar surrounded by four natural rubber cords encased in the main structural member of the axle beam. The wheel/hub spindle is attached to a lever, called the torsion arm assembly. This assembly includes the torsion arm, the torsion bar and spindle. As load is applied to the trailer, the torsion arm assembly pivots around the torsion bar, causing a rolling or compressive resistance in the rubber cords inside of the axle beam. Both sides of the axle are completely independent from one another.

### Direction of Travel

The rubber torsion axle beams and stub axles must be mounted with the torsion arm and spindle trailing to the rear of the axle beam.

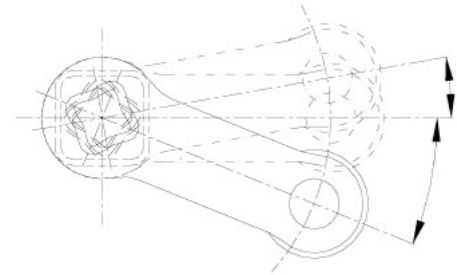

As Load is Applied to the Trailer, the Torsion Arm Moves to Absorb the Shock

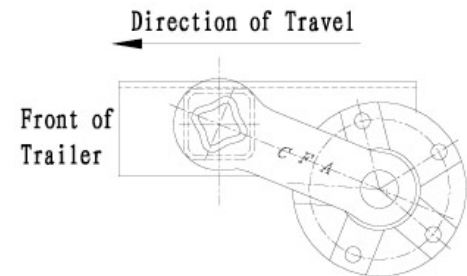

## Wheels and Tires

### Wheel Selection

Wheels are a critical component of your running gear system. When specifying or replacing your trailer wheels it is important that the wheels, tires, and axle are properly matched. The following characteristics are extremely important and should be thoroughly checked when replacement wheels are considered.

1. **Bolt Circle.** Many bolt circle dimensions are available and some vary by so little that it might be possible to attach an improper wheel that does not match the hub. Be sure to match your wheel to the hub.
2. **Capacity.** Make sure that the wheels have enough load carrying capacity and pressure rating to match the maximum load of the tire and trailer.
3. **Offset.** This refers to the relationship of the centerline of the tire to the hub face of the axle. Care should be taken to match any replacement wheel with the same offset wheel as originally equipped. Failure to match offset can result in reducing the load carrying capacity of your axle.

### Torque Requirements

It is extremely important to apply and maintain proper wheel mounting torque on your trailer axle. Torque wrenches are the best method to ensure the proper amount of torque is being applied to a fastener.

It is important that the specified torque levels are maintained on the wheel nuts or bolts on your axle to prevent loose wheels, broken wheel studs, and possible wheel separation from the axle.

Wheel nuts and bolts are offered in different cone angles (usually 60° or 90°). It is important to match the angle of the fastener to the wheel on the axle.

The proper procedure for the attachment of your wheels is listed at right.

1. Start all bolts or nuts by hand to prevent cross threading.
2. The tightening of the fasteners should be done in stages. Following the recommended sequence above, tighten fasteners per the wheel torque chart below.
3. Wheel fasteners should be torqued before the first initial road usage and after each wheel removal. Check and retorqued the wheel fasteners after the first 50 miles and again at 500 mile intervals. Check periodically thereafter to ensure that the proper torque values are maintained.

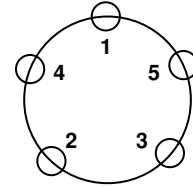

5 Bolt Pattern

<b>WHEEL TORQUE VALUES</b>			
<b>Wheel Size</b>	<b>1st Stage</b>	<b>2nd Stage</b>	<b>2nd Stage</b>
13"	20-25 ft./lbs.	35-40 ft./lbs.	*50-75 ft./lbs.







**Tires**

Like the tires on a car, the most important factor in the life of the tires on your trailer is their inflation pressure. The recommended tire inflation pressure is 30 PSI. Underinflation of tires will lead to added wear and tear and tire failure. During use of your trailer, inflation pressure should be checked weekly and performed when the tires are cold (prior to operation of the trailer). In doing this, you will ensure that you are achieving the maximum life and tread wear for your tires.

**Wheels and Tires – Inspection and Maintenance**

Wheels should be visually checked periodically for dents or cracks. Whenever it is required to have a tire replaced on a rim, the wheel needs to be checked for balance and distortion.

Tire wear should also be checked often for abnormal or excessive wear. The following chart will aid you in troubleshooting if abnormal or excessive tire wear should occur. It is important to monitor tire wear, as once a wear pattern becomes firmly established in a tire it is difficult to stop, even if the underlying cause is corrected.

<b>TIRE WEAR DIAGNOSTIC CHART</b>			
<b>Wear Pattern</b>	<b>Cause</b>	<b>Action</b>	
 Center Wear	Overinflated tire	Adjust tire pressure to specific load rating per tire catalog	
 Edge Wear	Underinflated tire	Adjust tire pressure to specific load rating per tire catalog	
 Side Wear	Loss of camber or overloading	Make sure load does not exceed axle rating. Realign axle at axle shop	
 Toe Wear	Incorrect toe-in	Align at alignment shop	
 Cupping	Out-of-balance	Check bearing adjustment and balance tires	
 Flat Spots	Wheel lockup	Avoid sudden stops when possible and adjust brakes and tire skidding	

***Maintenance Schedule***

Below is a maintenance schedule for routine maintenance of your trailer.

<b>Item</b>	<b>Function Required</b>	<b>500 Mile Intervals</b>	<b>3 Months or 1000 Miles</b>	<b>6 Months or 3000 Miles</b>	<b>12 Months or 6000 Miles</b>	<b>Refer to Page</b>
Hub/Drum/Rotor	Inspect for abnormal wear				●	—
Bearings (Sure Lube-Bearing Lube)	Replenish grease in the system				●	4
Seals	Inspect for leakage Replace if worn				●	—
Wheel Nuts and Bolts	Check torque values	●				6

# PARTS IDENTIFICATION

## Parts List Overview

Item	Description	Quantity
A	Floor and Sidewall Trailer Body Panels	4
B	5 x 4.5 Lug Pattern Torsion Axle with Autolube Fitting	1
C	Fenders	2
D	2" A-Frame Coupler	1
E	Safety Cables	2
F	84" x 1.625" C-Channels	2
G	56" x 23" U-Tubes	8
H	84" x 2" x 2" Frame Tubes	2
I	55" x 2" x 2" A-Frame Tubes	2
J	2" x 2" x 48" Frame Angle	1
K	13" Tire & Wheel Assembly ST 175/80D13 Tire & Wheels	2
L	84" Radius Steel Corner Cover	2
M	Stud Mount Passenger Tail Light without License Illuminator	1
N	Stud mount Driver Tail Light with License Illuminator	1
O	Amber Lights, Front Marker Light	2
P	L-Bend Bolt On Light Brackets	2
Q	License Plate Triangular Plate	1
R	4-Flat Wire Lighting Harness with Four-Flat Connector	1
S	End Gates	2
T	M8 Snap Pins	4
U	1-1/2" Wide End Gate Support L-Brackets (Fits Inside Trailer Frame Tube)	4
V	1" Wide Steel Angle End Gate Brackets (Fits Trailer Body)	4
W	2" Wide Steel Angle End Gate Brackets (Fits End Gates)	4
X	Pin Nut Assembly Kit: M8 x 25.4 Bolts, M8 Flat Washers, M8 Split Ring Lock Washers	16
Y&Z	Spring Nut, L-Bracket, Hardware Kit:	
Y	M8 Spring Nuts with M8 x 45 Bolts, Washers	2
Z	M12 Spring Nuts with M12 x 20 Bolts, Washers, Split Ring Lock Washers	2
AA	Self Drilling Screws	28
BB	M12 x 80 Bolts	10
CC	M12 x 130 Bolts	2
EE	M12 Flat Washers	24
FF	M12 Nylon Lock Nuts	12
LL	M8 x 40 Bolts	20
MM	M8 x 100 Bolts	12
RR	M8 x 45 Bolts	6
	M12 Lock Washers	
	M8 Washers	
	M8 Flat Washers & Stainless Steel Flat Washers	
	M8 Lock Nuts	
	M8 Split Ring Lock Washers	
	Plastic Ties	
	Split plastic convoluted wire conduit	

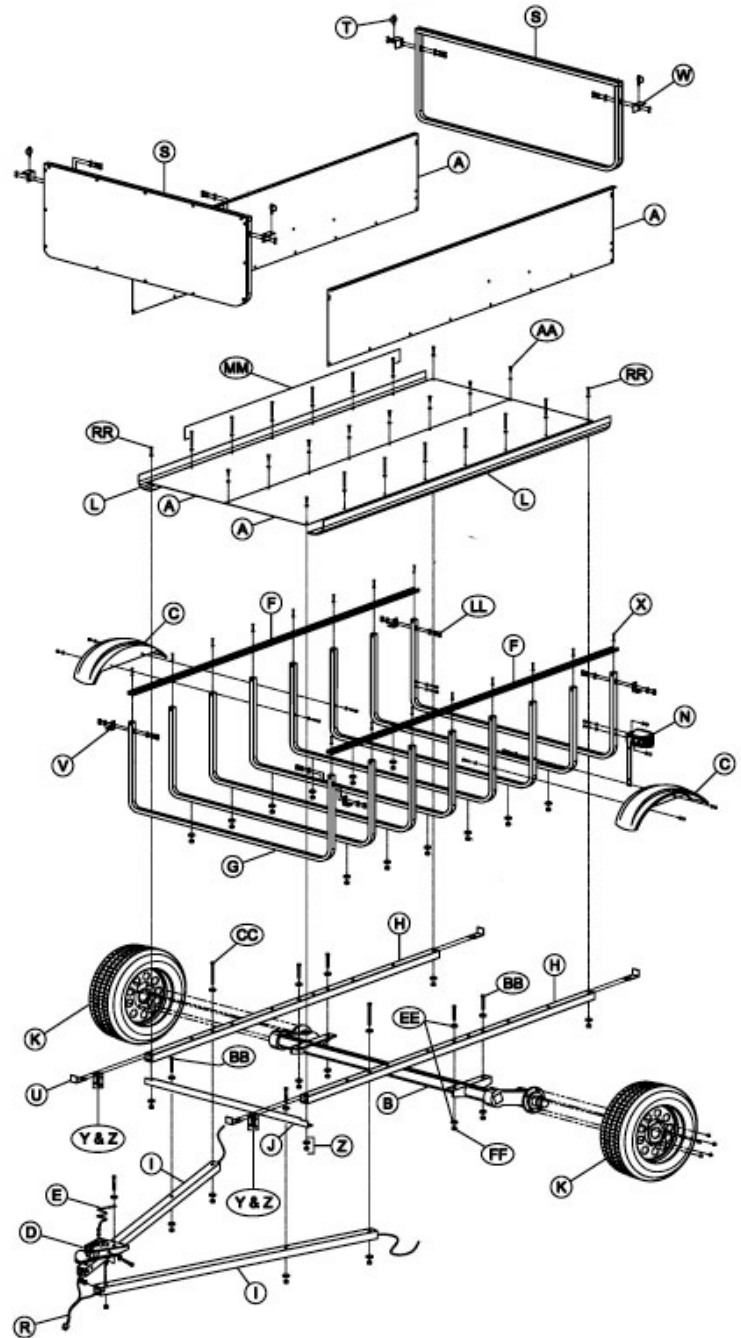

For ease of assembly, small hardware parts are kitted and marked by assembly step. Below is a description of parts and quantities:

**Description** **Quantity**

**Step 2**

M12 x 80 Bolt	4
M12 Flat Washers	8
M12 Nylon Lock Nuts	4

**Step 3**

Spring Nut, L-Bracket, Hardware:

M8 Spring Nut	2
M12 Spring Nut	2
M12x20 Bolt	2
M12 Lock Washer	2
M12 Flat Washer	2
M8x45 Bolt	2
Star Lock Washer (Supplemental Kit)	2
Endgate L-Bracket	2

**Step 4**

M12x80 Bolt	2
M12x130 Bolt	2
M12 Lock Nut	4
M12 Flat Washer	8

**Step 5**

M12x80 Bolt	4
M12 Lock Nut	4
M12 Flat Washer	6
Safety Cable Washers (Big)	2

**Step 7 & 8**

M8x100 Bolt	12
M8 Flat Washer	28
M8 Lock Nut	14
M8x45 Bolt	2
Endgate Support L-Bracket	2
Pin Nut Assembly Kit:	
M8x25.4 Bolt	16
M8 Stainless Steel Flat Washer	16
M8 Stainless Steel Split Ring Washer	16
Pin Nut	16
7' Black Foam Tape (1/4" x 1/2")	2

**Step 10**

Self Drilling Screw	12
M8 Flat Washer	12
External Tooth Lock Washers (Supplemental Kit)	12

**Step 11**

Self Drilling Screw	16
M8 Flat Washer	16
External Tooth Lock Washers (Supplemental Kit)	16

**Step 12**

M8x40 Bolt	8
M8 Flat Washer	8
M8 Lock Nut	8
1" Endgate Support Bracket	4

**Step 13**

M8x40 Bolt	8
M8 Flat Washer	8
M8 Lock Nut	8
2" Endgate Support Bracket	4

**Step 14**

Snap Pin	4
----------	---

**Step 15**

Split plastic convoluted wire conduit (Supplemental Kit)

**Step 16**

M8x40 Bolt	4
M8 Flat Washer	8
M8 Lock Nut	4

**Step 18**

M8x45 Bolt	4
M8 Flat Washer	4
M8 Lock Nut	4
1.25" / M8x30 Fender Washers	2
2" / M8x50 Fender Washers	2
(Supplemental Kit)	

**Supplement Parts Kit is included with additional nuts and parts required for assembly (located in a separate box inside crate, labeled).**

<b>Tools Needed</b>
<p>13 mm Socket Wrench                  18 mm Socket Wrench                  18 mm Box Wrench                  M18 Box Wrench                  Lug Wrench                  5/16 Nut Driver                  #2 Phillips Screwdriver                  Drill for Self Drilling Screw</p>

## LITTLEGIANT TRAILER™ ASSEMBLY

### Important Notice on Assembly Tightening of Trailer's Under Carriage:

The LittleGiant Trailer (LGT) is a precision built product and some consideration of "alignment" is necessary when first assembling the trailer's under carriage. The LGT uses "symmetry" in a balanced manner, so when bolting the under carriage together for the first time, tighten all hardware in a two step process. First, tighten the trailer frame assembly to set the components in position, referred to as "Assembly Fit". Final Tightening occurs at Step 9. Final Tightening of M8 bolts should be to 15 foot lbs of torque. Final Tightening of M12 bolts should be to 45 foot lbs of torque.

## 1. Unpack Crate for Assembly

Remove the trailer parts from the crate. Remove the four 84" steel trailer body panels (nested underneath the wood crate). Note that the 84"

C-Channels are located inside the Frame Tubes for removal.

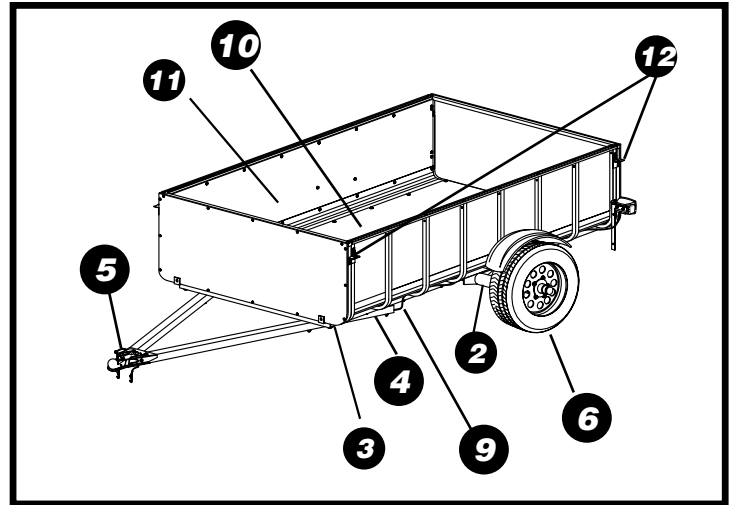

## 2. Attach Frame Tubes to Axle

Locate the Torsion Axle (B) and the two Trailer Frame Tubes (H) in the parts kit. **Orient the Frame Tubes with the M8 holes facing upward at the front of the tubes as noted** (the M12 holes will correctly position downward accordingly).

Place the Trailer Frame Tubes over the mounting brackets on the axle and line up the holes in the tubes with the holes in the brackets.

Secure the tubes to the axle with four (4) M12 x 80 Bolts (BB), eight (8) M12 Flat Washers (EE) and four (4) M12 Nylon Lock Nuts (FF). **Tighten the hardware for "Assembly Fit", but wait until later in the assembly process to "Final Tighten" this hardware.**

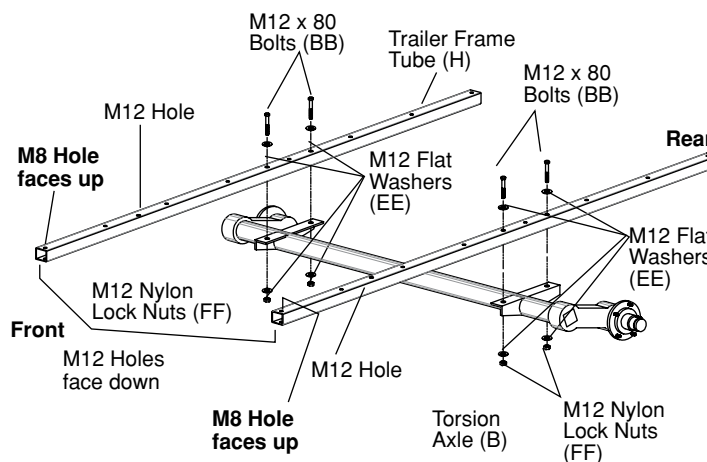

### 3. Install Endgate Support Brackets

Locate the Frame Angle (J), the Spring Nut, L-Bracket, Hardware Kit (Y&Z), and two (2) of the End Gate Support L-Brackets (U) in the parts kit.

Start from the front (hitch side) of the trailer and place an M8 Spring Nut (Y) and an M12 Spring Nut (Z) together inside the end of each Trailer Frame Tube with the M8 Spring Nut facing up and an End Gate L-Bracket (U) inserted between the M8 Spring Nut and the top of the frame tube. Attach the Frame Angle (J) to the bottom of each frame tube with a M12 x 20 Bolt, M12 Lock Washer and M12 Flat Washer. Tighten this hardware for "Assembly Fit" (Final tighten later).

Insert the M8 x 45 Bolts and M8 Lock Washers from the **Supplemental Parts Kit** (use in place of the Flat Washers from the M8 Spring Nut assemblies) through the top of the Frame Tubes to hold the Spring Nuts in place.

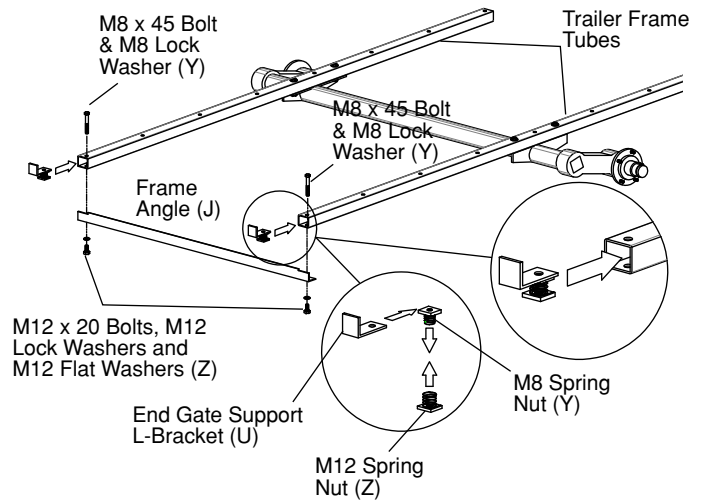

### 4. A-Frame Tubes & Wiring

Locate the two (2) A-Frame Tubes (I), the 4-Flat Wire Lighting Harness (R), two (2) M12 x 80 Bolts (BB), two (2) M12 x 130 Bolts (CC), four (4) M12 Nylon Lock Nuts (FF) and eight (8) M12 Flat Washers (EE) in the parts kit.

#### Orient the A-Frame Tubes with:

1. The single set of holes on the sides positioned toward the front. These holes are not centered vertically along the sides and should be positioned close to the top of the tubes as shown below.
2. The Tube with Warning Labels **MUST be positioned on the Driver Side and facing outward in accordance with NHTSA law.**

#### Wiring:

Slide the driver and passenger wire harness lengths through the A-Frame tubes **with the solid yellow lead on the driver side and the solid green lead on the passenger side.**

Mount the A-Frame Tubes under the LGT frame assembly using the sets of M12 hardware as shown. Tighten these four (4) hardware sets for Assembly Fit.

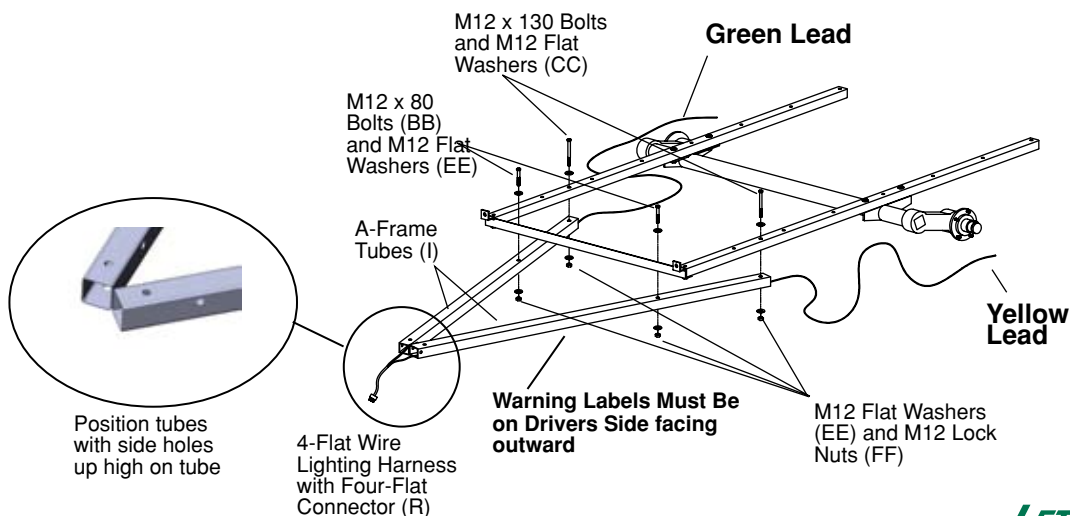

## 5. Install A-frame Coupler and Safety Cables

Locate the A-Frame Coupler (D), the two (2) Safety Cables (E) and four M12 x 80 Bolts (BB), four (4) M12 Nylon Lock Nuts (FF) and six (6) M12 Flat Washers (EE), and two (2) M12 Bigger Flat Washers for Safety Cable area as noted below.

Attach the A-Frame Coupler (D) to one of the A-Frame tubes and install the Safety Cable in the [side](#) hole. Install a M12 x 80 Bolt, M12 Nylon Lock Nut and two (2) M12 Flat Washers in both the top and side holes of the coupler. Repeat this with the other A-Frame Tube. Tighten this hardware for Assembly Fit (Tighten later).

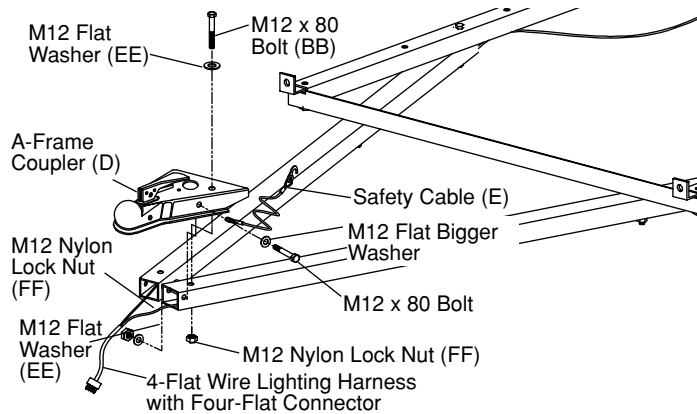

## 6. Install Wheels

Install the wheels on the axle. Tighten the lug nuts to 50 to 75 foot pounds. Refer to the Wheels and Tires Section of this manual. After using the trailer for 50 miles, re-check the lug nuts to insure they have remained tight.

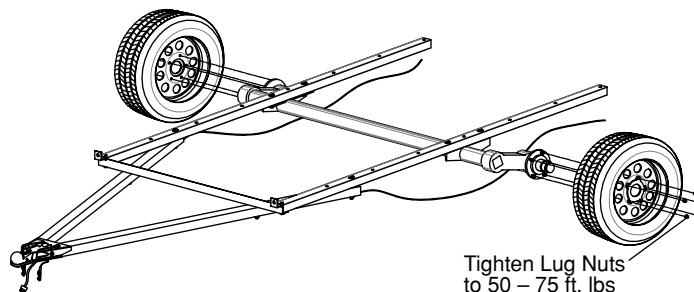

## 7. Install U-Tubes and Side Panels

Locate the U-Tubes, two (2) M8 x 45 Bolt assemblies (RR), twelve (12) M8 x 100 Bolt assemblies (MM) and sixteen (16) Pin Nut assemblies in the parts kit (X).

**The U-Tubes numbered 1, 5, 6 and 8 MUST be installed in these positions counting from the front (hitch side) to back. The remaining U-Tubes are not numbered and may be placed in any position.**

Remove the bolts in the front holes (nearest the hitch) in the Frame Tubes. Place U-Tube #1 over these holes and secure it with the bolts. Place U-Tube #8 over the rear holes and use the two (2) M8x45 Bolts (RR) to hold it to the Frame Tubes.

Use the twelve (12) M8 x 100 Bolt assemblies (MM) and use the bolts to hold the remaining U-Tubes to the Frame Tubes. Do not install the washers and nylock nuts at this time.

**Important: All bolts will fit properly if the undercarriage is square. The undercarriage has a loose fit to allow for adjustment at this stage if it is necessary.**

Once the U-Tubes are mounted on the Frame Assembly in the proper order, remove the M8 x 25.4 Bolts from the Pin Nut assemblies (X) and set the bolts and other hardware aside. Place a Pin Nut into the openings in the top of each U-Tube. Align the slot in the Pin Nut with the side of the U-Tube so that the side of the tube will go into the nut when it is tightened. If necessary, lightly tap the Pin Nut into place with a plastic hammer to avoid damaging the Pin Nut.

Locate the 84" x 20" side panels (not interchangeable) and position the 1" panel return on top of the U-Tubes, with the 20" portion of panel resting on the inside of the U-Tubes.

Place the two C-Channels on top of U-Tubes/panel profile and install the sixteen (16) bolts and hardware from the Pin Nut assemblies (M8x25.4 Bolts, Stainless Steel Flat Washers, Lock Washers). Thread the bolts through the C-Channels, side panels and into the Pin Nuts.

Secure all hardware for Assembly Fit (Tighten later).

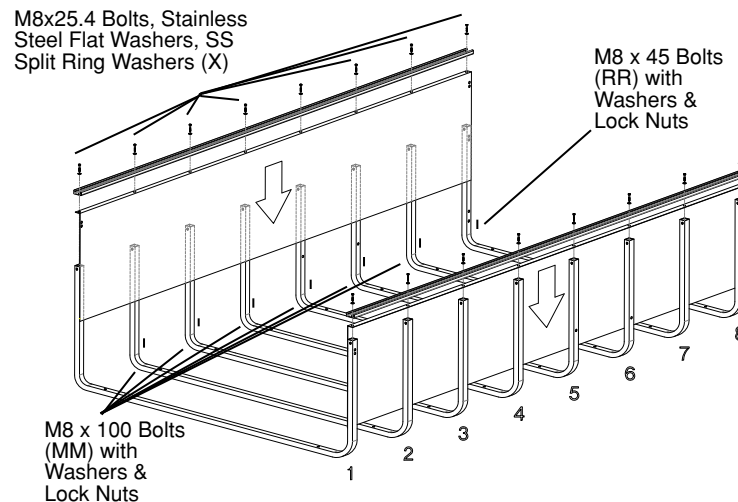

## 8. Install Floor Panels and Corner Covers

Locate the 24" x 84" Floor Panels, two (2) remaining 1-1/2" Wide End Gate Support L-Brackets (U) and the two (2) 84" Radius Steel Corner Covers (L) in the parts kit.

Remove the M8x100 Bolts that secure the eight U-Tubes to the Frame Tubes on one side. Place one of the 24" x 84" Floor Panels on top of the U-Tubes. Place a 1-1/2" Wide End Gate Support L-Bracket into the rear ends of the Frame Tubes. Reinstall the bolts, starting with U-Tube #1 to secure the Floor, Support L-Bracket and U-Tube to the Frame Tube. Then reinstall the M8 x 45 Bolt (RR) in U-Tube #8 using the M8 Washers on the top and the M8 Flat Washers and Lock Nut on the bottom to secure the Floor, Support L-Bracket and U-Tube to the Frame Tube.

Once the #1 and #8 U-Tubes are secure, reinstall the M8 x 100 Bolts, Washers, and Lock Nuts (MM) in the same manner.

**Important: Make sure that the floor panels are square with U-Tubes 1 and 8 before setting screws. Adjust the undercarriage if necessary.**

Clean the inside top edge of each 84" Radius Steel Corner Cove with a 50/50 solution of rubbing alcohol and water (not supplied) or similar degreaser. Apply a length of the black foam along the top edge. The top edge has eight holes along its length. **Slip the Corner Covers top edge under the Side Panel and beneath the floor panel until it contacts the bolt shafts.**

Tighten the bolts for Assembly Fit. Repeat this on the other side of the trailer.

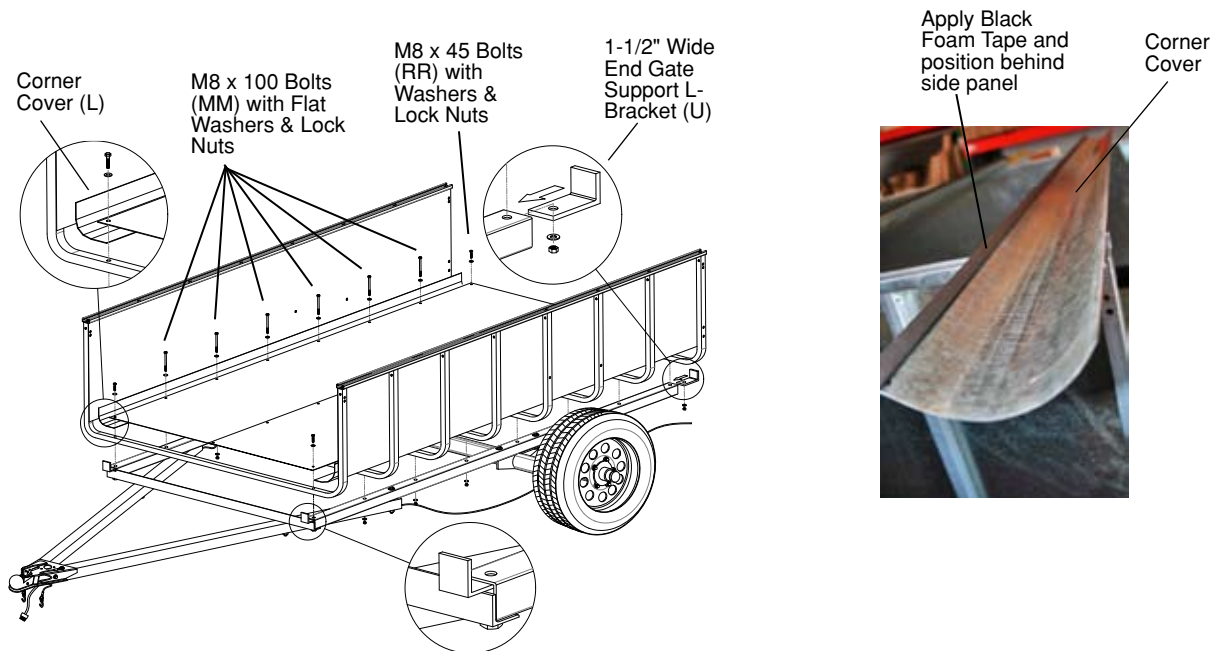

## 9. Tighten Bolts

Once all the U-Tube/Floor mounting bolts are installed and assembly tightened, tighten these bolts to a final torque of 15 foot pounds.

**Final Tighten the remaining hardware on the trailer frame, torsion axle and coupler. Final tightening of M8 bolts should be to 15 foot lbs of torque, and to 45 foot lbs of torque for the M12 bolts.**

## 10. Install Body Fasteners

Locate the twelve (12) Self Drilling Screws (AA) in the parts kit and the twelve (12) External Tooth Lock Washers in the Supplemental Parts Kit (for use instead of plastic washers on the self-tapping screws). Use the pre-drilled holes in the center of the floor panels and at front and rear center of panel locations as a guide to engage and tighten the self drilling fasteners through the floor panels and into the U-Tubes with an electric drill and a 5/16" nut driver.

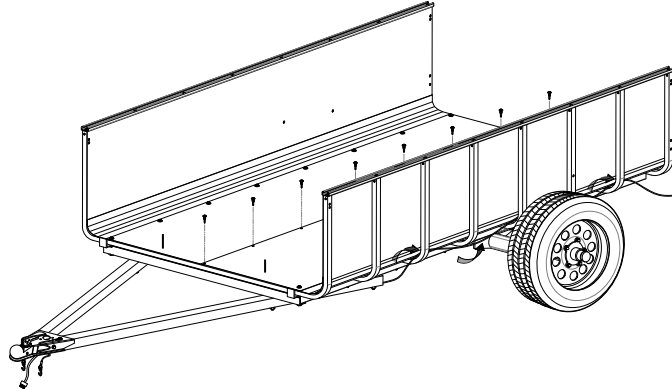

## 11. Secure Side Panels

Use the pre-drilled holes in the top of the corner cove and bottom of the side panel as a guide to install sixteen (16) Self Drilling Screws (AA) with sixteen (16) External Tooth Lock Washers in the Supplemental Parts Kit (for use instead of plastic washers on the self-tapping screws) to secure the corner cove and side panel to the U-Tubes with a 5/16" nut driver. For best results apply only a little pressure when installing the screws. Repeat on opposite side.

**The side panels are NOT interchangeable.** There is a passenger and a driver side panel. To place correctly, **make sure the two holes near the center of each sidewall (for mounting the fenders) match up with the holes in the #5 and #6 U-Tubes.**

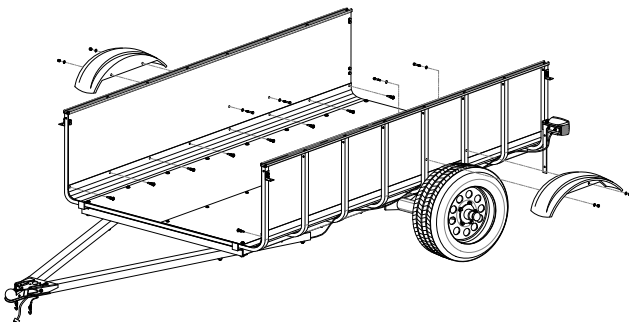

## 12. Install Side Body Latches

Use the holes in the outside of the #1 and #8 U-Tubes as guides to install 1" End Gate Support Brackets (V) in these holes on the outside of the U-Tubes using eight (8) M8 x 40 Bolts (LL), M8 Washers, and M8 Nylon Lock Nuts.

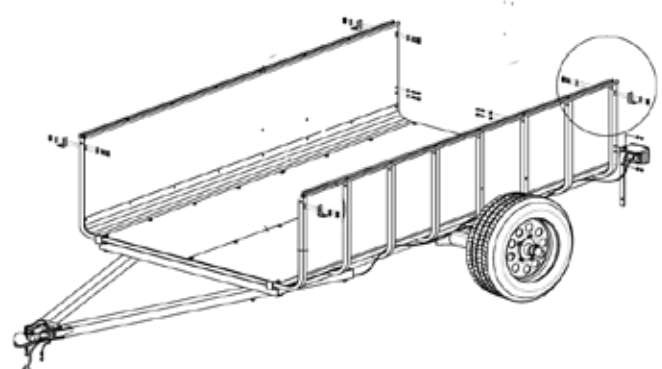
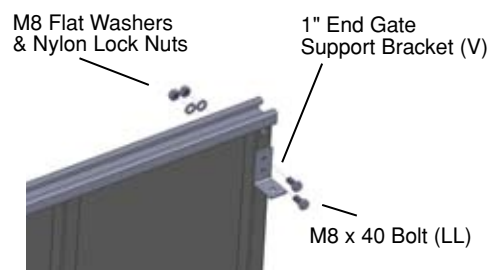

### 13. Install Endgate Side Latch & Position Endgate

Locate the 2" End Gate Latch Angles (W), eight (8) M8x40 Bolts (LL), eight (8) M8 Nylon Lock Nuts, eight (8) M8 Flat Washers (HH) and the four (4) Snap Pins (T).

Loosely install the End Gate Latches as shown. Use the Snap Pins to check

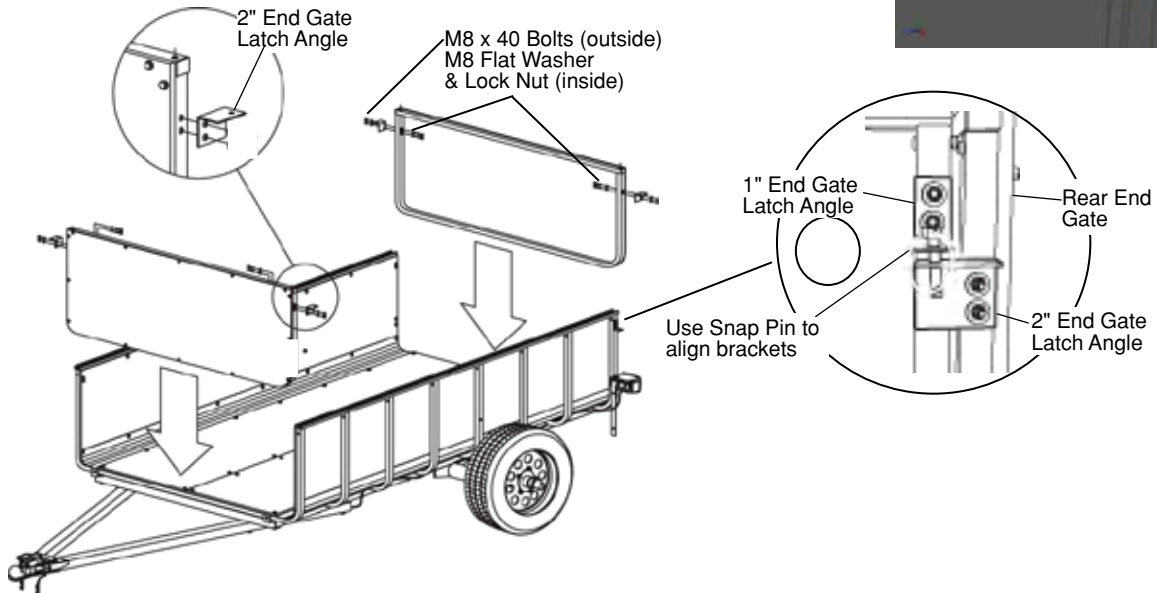

### 14. Insert Snap Pins

Insert the M8 Snap Pins (T) into the End Gate Latch Angles.

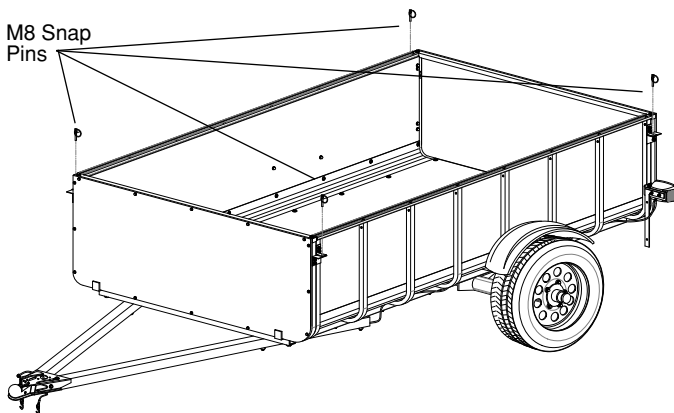

### 15. Wiring: Routing and Connections

**Make sure that the solid yellow lead is on the driver's side and the solid green lead is on the passenger side per Step 4.**

Apply wire conduit on all visible portions of the wiring, and where the wire may rub against other parts of the trailer. The conduit will not cover the wire connectors. You may wish to seal with plastic ratchet ties the ends of any of these connectors that are positioned in an exposed location.

Where the wire harness exits the A-Frame, weave the loose ends of the wire harness in and out of the U-Tubes

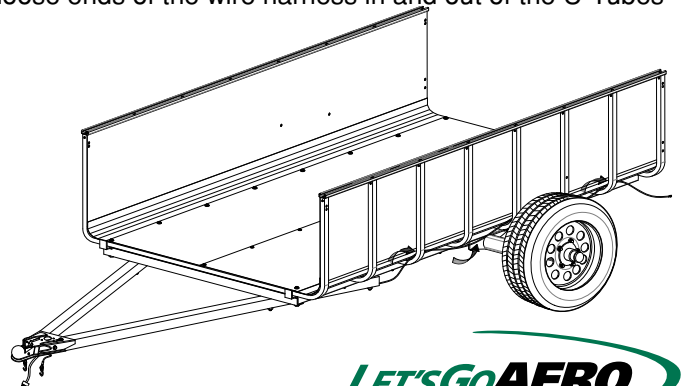

## 16. Light Assembly

Locate the Light Assemblies and remove the hardware furnished on the assemblies. Use this hardware and an 11 mm deep socket wrench to install the rear signal and brake lights and license.

Place the L-Bracket furnished with the taillight with license plate illuminating window so the Bracket is pointing outward and is flush with the rear of the U-Tube on the driver side. Orient it with the illuminated fixture down.

Use the holes in the U-Tube as a guide to drill holes through the side panel. Use two (2) M8 x 40 Bolts (LL), two (2) M8 Flat Washers (HH) and two (2) M8 Nylon Lock Nuts (JJ) to install the L-Bracket to the U-tube.

Hold the light fixture in your hand and route the wires into the wire channel on the back of the fixture. From the channel, wrap the white wire's metal loop around the left hand post on the back of the light. Then insert the brown wire into the second hole from the right. Insert the green or yellow wires into the third hole from the right.

To secure the wiring in the fixtures, twist the end of each wire and insert it down into the hole. If a wire does not lock into place, simply remove it and try again.

Place the License Triangular Plate between the Bracket and the light fixture with the point down. Secure it with the Nut from the Light Assembly Hardware.

Repeat this procedure on the passenger side without the License Triangular Plate.

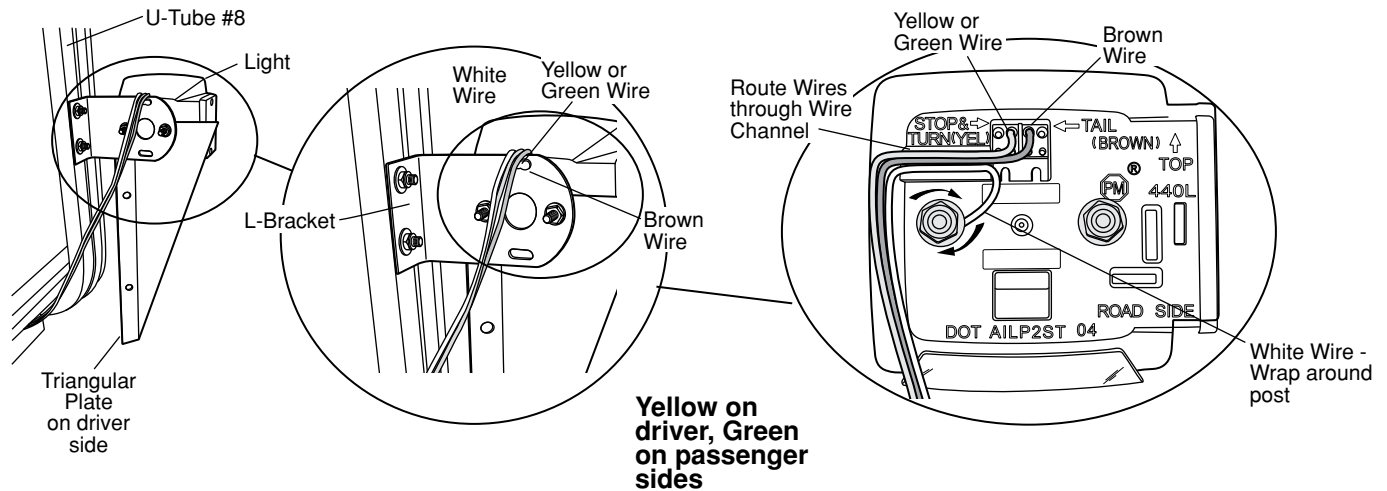

## 17. Install Side Marker Lights

The left and right Amber Front Side Marker Lights plug into the wire harness. Each marker light has two plugs, which are interchangeable. Locate the corresponding plugs on the Wire Harness, and route the Light along with the Wire Harness through the A-Frame Tube. Using two self tapping screws\*, attach each side marker light base to the main frame tube. Then, press the light onto the base.

Apply plastic tie for added connectivity of wire to trailer body.

\* You may reuse the four hex head screws from the shipping crate, or those supplied in the Supplemental Parts Kit.

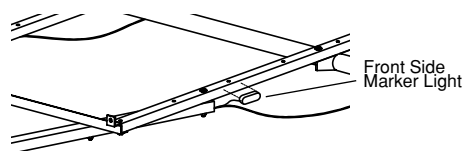

## 18. Install Fenders

Locate the Fenders, four (4) M8 x 45 Bolts, four (4) M8 Lock Nuts, four (4) M8 Flat Washers, (2) 2" / M8x50 Fender Washers, and two (2) 1.25" / M8x30 Fender Washers (from Supplemental Parts Kit).

Use the holes in the outside of the #5 and #6 U-Tubes as guides to bolt the fenders through the U-Tubes and Side Panels. Align the holes in the Fenders with the holes in the Side Panels and install the Fenders as shown.

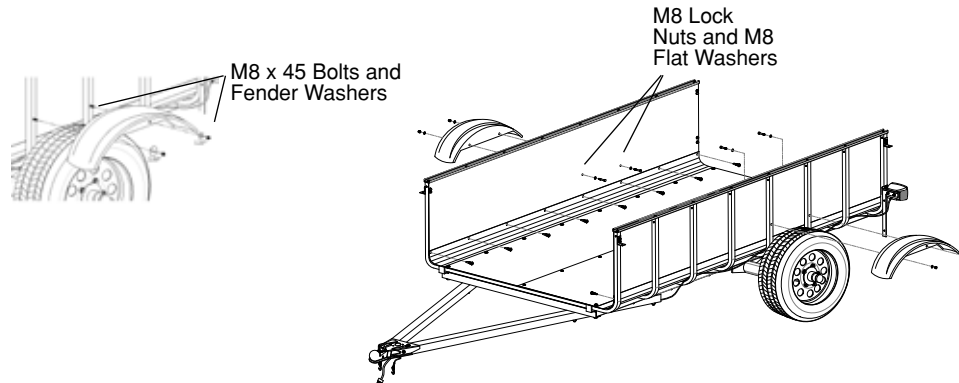

## 19. License Plate Installation

Install license plate vertically on the triangular plate as shown on the drivers side. Use the two holes on the side as a guide and tighten using 2 nuts and bolts (not provided).



## Tuning Tips

If you will be using your Littlegiant Traler for light loads (under 750 lbs), the 30 psi recommended tire pressure can be reduced to 22 psi to further enhance the trailer's soft ride.

## Trailer Licensing Notice

Some states may consider this trailer a vehicle requiring registration, licensing, and titling. In many states, you will need the Manufacturers Certificate of Origin filled out and signed by the dealer transferring ownership to you (the reseller from whom you purchased this trailer). Take this M.C.O. along with your bill of sale (cash register receipt) to your local DMV. Once you pay the appropriate fees, you will be issued a title or registration and license plate. Some states may require inspection of the assembled trailer before issuing a title, registration, or license. Check with your State Department of Motor Vehicles for information and guidance on registering, licensing, and titling the trailer.

**Motor Vehicle law requires that the reseller sign over the Manufacturer's Certificate of Origin to the buyer. The reseller is the dealer from whom the trailer was purchased by the buyer. Please contact your dealer for assistance in obtaining your M.C.O from them.**

## Let's Go Aero Warranty/Repair Procedures

Let's Go Aero offers a 1 year limited warranty to each new Let's Go Aero trailer against manufacturing defects in workmanship and materials.

The obligation under this warranty is limited to the replacement or repair at the manufacturer's factory, or at a point designated by the manufacturer, of such part as shall appear to the manufacturer upon inspection of such part to have been defective in material or workmanship. This warranty does not obligate Let's Go Aero to bear the cost of labor or transportation charges in connection with the replacement or repair of defective parts, nor shall it apply to a product upon which alterations have been made or for equipment misused, neglected or improperly installed.

Let's Go Aero reserves the right to improve any product through changes in design or materials as it may deem desirable without being obligated to incorporate such changes in products of previous manufacture.

Bills for service, labor, or other expenses which have been incurred by the buyer without express approval or authorization by Let's Go Aero will not be accepted.

If your trailer fails to operate properly, or fails within the warranty period, the following steps should be taken:

1. An RMA is required for any return of product for warranty work of defective components. Contact Let's Go Aero for an RMA, toll free 877-464-2376, toll 719-630-3800, or via email to [contact@letsgoaero.com](mailto:contact@letsgoaero.com). Freight must be prepaid – collect shipments will be refused. Include your RMA number, name, return address, phone number and a description of the problem. A copy of the receipt including date of purchase is necessary for any warranty claim.
2. If damages are due to abuse or misuse, owner will be charged for parts and labor.
3. If any of the components of your trailer are found to be faulty due to defective material or workmanship, they will be repaired at no charge and returned with transportation charges prepaid. If failure occurred because of abuse, neglect or misuse, an estimate of cost to repair will be submitted back to the owner. After repairs are completed, the material will be returned with transportation charges collect.

Any modifications made to the trailer or parts of the trailer will void the trailer warranty and release Let's Go Aero of any responsibility for damages, injuries or accidents incurred.

For further information and customer assistance, call toll free, 1-877-464-2376 or 719-630-3800.